



Questions & Answers about LubeMinder®

Why is it necessary to oil my chains and sprockets?

You should consistently lubricate your chain drives for six important reasons.

1. To resist friction and wear between moving parts.
2. To flush away dirt and foreign material.
3. To lubricate chain-sprocket contact surfaces.
4. To retard rust and corrosion.
5. To carry heat away from bearings.
6. To cushion load impact areas of running parts.

If I manually oil my chains every day, why do I need the Automatic LubeMinder®?

To answer this you need to look at the chain assembly. A chain is a series of traveling metal bearings requiring proper lubrication to give maximum service. The lubrication forms a separating wedge between the pins and bushings in the chain joints—much like that formed in journal bearings. Oil applied manually to the rollers will not flow between the chain link plates and fill the critical pin bushing joints—ultimately causing constant metal-to-metal contact and debris build-up. As a result of this build-up, chain elongation or “stretch” occurs. Metal wear and debris build-up cause a small distortion at the load area on every pin bushing. A #60 chain has 36 pin bushings per foot. Over a 15 foot length—that equals 540 potential distortion points. This condition directly affects your equipment. As the chain gets longer—it rides too high on the sprocket and often the sprocket teeth begin to look like a wheat sickle. The affected sprockets can then cause timing problems or chain and teeth breakage—resulting in costly down time for you and your equipment.

How can the LubeMinder® increase the life of my chains and sprockets?

The LubeMinder® applies oil when the chain is warm and running. This is the best time to apply lubricant because you get the proper penetration. Consistent oiling minimizes metal-to-metal contact and provides cooling. Oil pumped to a brush located next to the chain maximizes the amount of debris cleaned off the chain while it disperses the oil to the pin bushing joint to help eliminate chain stretch.

Is the LubeMinder® adjustable?

YES. We preset the LubeMinder® at the factory to deliver the maximum amount of oil. Simply turning the brass adjusting screw will modify the oil dispensing rate to fit your specific operating conditions.

How long does a full reservoir last?

On average—the two-quart reservoir will last approximately 8 hours. This rate will vary by the way you adjust the pumps dispensing rate and the number of cycles your equipment uses.

What does a LubeMinder® kit contain?

The LubeMinder® has all the parts needed to install on round balers, combines, mower-conditioners, shredder attachments and other hydraulic-activated sprocket-chain equipment. Even the drill bit to drill the correctly-sized holes comes in the kit. All you add is your own tools. You also need to purchase two quarts of the appropriate SAE chain oil for your conditions. (See section on recommended oils.)

How long will it take to install a LubeMinder® on my equipment?

A dealer will require 1 to 1-1/2 hours to install the LubeMinder®. If you are installing the kit in the field, installation time will vary with the type of machine and conditions.

What type of oil should I use?

The type of oil is as important as the method of application. Most chain manufacturers recommend a good grade of clean petroleum chain oil without additives. Additives generally leave a varnish or gum residue which prevents oil from penetrating the chain joints. The highest viscosity oils flow best between the chain link plates, filling the pin-bushing areas—providing the best wear life. The following table identifies lubricant viscosity recommended for various temperatures.

20-40 F	SAE20	40-100 F	SAE30	100-120 F	SAE40	120-140 F	SAE50
---------	-------	----------	-------	-----------	-------	-----------	-------

How does the LubeMinder® cycle?

LubeMinder® cycles by tying into any double-acting hydraulic cylinder on your equipment. For example, on a combine, you would use the cylinder which swings the unloader auger back and forth. On a round baler, use the cylinder which opens and closes the tailgate. On a mower-conditioner, use the cylinder which raises and lowers the cutting head.

Does the LubeMinder® use hydraulic fluid?

It uses hydraulic fluid only to actuate the LubeMinder® pump within a closed system.

HOW DOES THE LUBEMINDER® WORK

The **LubeMinder®** operates from any intermittent hydraulic signal. The pilot signal hose can be connected to a linear actuator, valve block, or manifold that does not trap pressure.

The **LubeMinder®** is cycled when the pilot signal is present. The hydraulic pressure pushes the piston up - compressing the gravity fed lube oil in the pump body. The pressurization forces the ball check from the lube supply to seat. As the pressure builds the lube oil is forced out to the manifolds opening the line checks, dispensing a light thin film of oil to the brushes. The stroke is adjustable by turning the piston rod in, limiting the stroke.

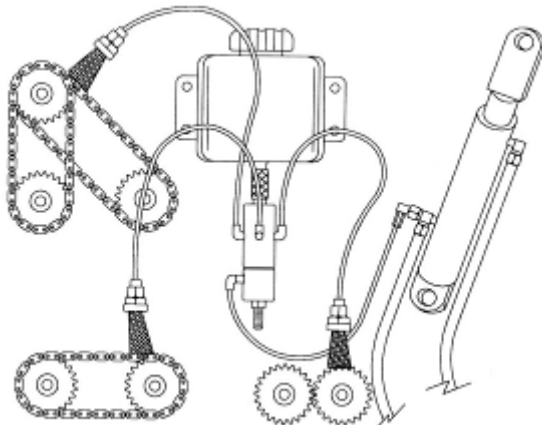

Below is a typical installation on a Round Baler. The LubeMinder® is spliced into the line that runs to the rear gate lift cylinder. Each time the rear gate is cycled the machine is oiled.

Key to numbers on schematic:

1. Oil Reservoir Tank.
Bolted to the sheet metal of the Baler
2. LubeMinder® Unit & Manifold Valve.
Feeds oil to individual brushes.
3. Hydraulic feed from the Tractor.
4. Brush lubricating the main drive chains
5. Brush lubricating the bale rolling chains
6. A Hydraulic line leading from the Hydraulic Cylinder to the LubeMinder® unit

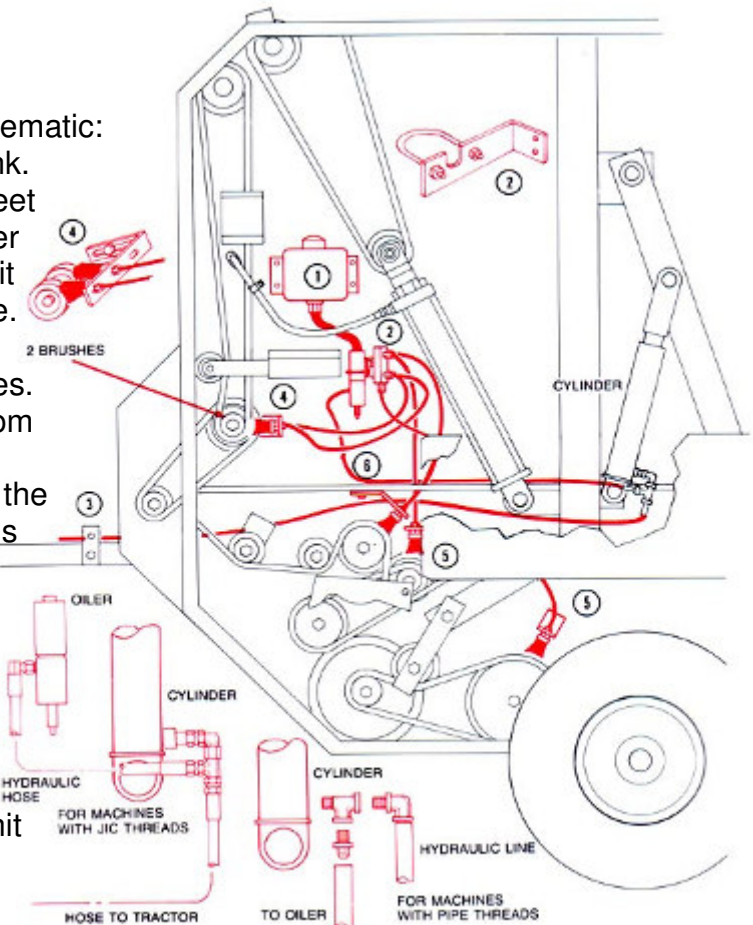

Suburban Manufacturing, Inc.

301 Chelsea Road, Monticello, Minnesota, USA 55362

1-800-782-5752 (763) 295-5635 Fax (763) 295-6601

www.gosuburban.com